

GEN-2008-092
Impact Restudy for
Generator Modification
(Turbine Change)

February 2015
Generator Interconnection



Executive Summary

The GEN-2008-092 Interconnection Customer has requested a modification to its Generator Interconnection Agreement to change from one hundred eighteen (118) GE 1.7MW wind turbine generators (aggregate power of 200.6MW) to one hundred twelve (112) GE 1.79MW wind turbine generators (aggregate power of 200.48MW). The Interconnection Request was originally studied with one hundred thirty-four (134) GE 1.5MW wind turbine generators. Since the GE 1.79MW wind turbine generator has identical electrical characteristics as the GE 1.5MW wind turbine generator, a stability analysis assessment was not performed for this change request. The results of the system impact study¹ performed for GEN-2008-092 are still valid for this generation interconnection request. As the original request for interconnection is for 201.0MW, the requested change is not considered a Material Modification.

Even though a restudy of the stability analysis was not performed for this interconnection change request, a reduced generation analysis was performed to account for collector system changes. The reduced generation (due to unsuitable wind speeds, curtailment, etc.) analysis shows the need for approximately 12.4MVAR of reactor support on the 34.5kV side of the Customer's substation transformer. The reactor support may be in the form of external reactive devices or through the use of the GE wind turbine WindFREE™ Reactive Power option.

Power factor requirements for GEN-2008-092 can be found in the previous system impact study, are listed in its Generator Interconnection Agreement, and are still valid for this change request.

With the assumptions outlined in this report and with all required network upgrades shown in the Generator Interconnection Agreement in place, GEN-2008-092 with the GE 1.79MW wind turbine generators should be able to reliably interconnect to the SPP transmission grid.

Nothing in this study should be construed as a guarantee of transmission service. If the Customer wishes to obtain deliverability to a specific customer, a separate request for transmission service shall be requested on Southwest Power Pool's OASIS.

¹ *Group 11 System Impact Study Report* performed by Pterra Consulting in the Southwest Power Pool (SPP) *Definitive Interconnection System Impact Study DISIS-2009-001* posted 1/31/2010.

1. Introduction

The GEN-2008-092 Interconnection Customer has requested a modification to its Generator Interconnection Agreement to change from the GE 1.7MW wind turbine generators to the GE 1.79MW wind turbine generators. In a previous system impact study, GEN-2008-092 was studied with one hundred eighteen (118) GE 1.7MW wind turbine generators (aggregate power of 200.6MW). The requested change is to use one hundred twelve (112) GE 1.79MW wind turbine generators (aggregate power of 200.48MW). The Interconnection Request was originally studied with one hundred thirty four (134) GE 1.5MW wind turbine generators. Since the GE 1.79MW wind turbine generator has identical electrical characteristics as the GE 1.5MW wind turbine generator, a stability analysis assessment was not performed for this change request. The results of the previous system impact study performed for GEN-2008-092 are still valid for this generation interconnection request. As the original request for interconnection is for 201.0MW, the requested change is not considered a Material Modification.

Even though a stability analysis was not performed for this interconnection change request, a reduced generation analysis was performed to account for the change in the collector system.

Nothing in this study constitutes a request for transmission service or grants the Interconnection Customer any rights to transmission service.

2. Facilities

Generating Facility

The point of interconnection (POI) for the GEN-2008-092 interconnection request is the Knoll 230kV substation. **Figure 2-1** depicts the one-line diagram of the local transmission system including the POI as well as the power flow model representing the request.

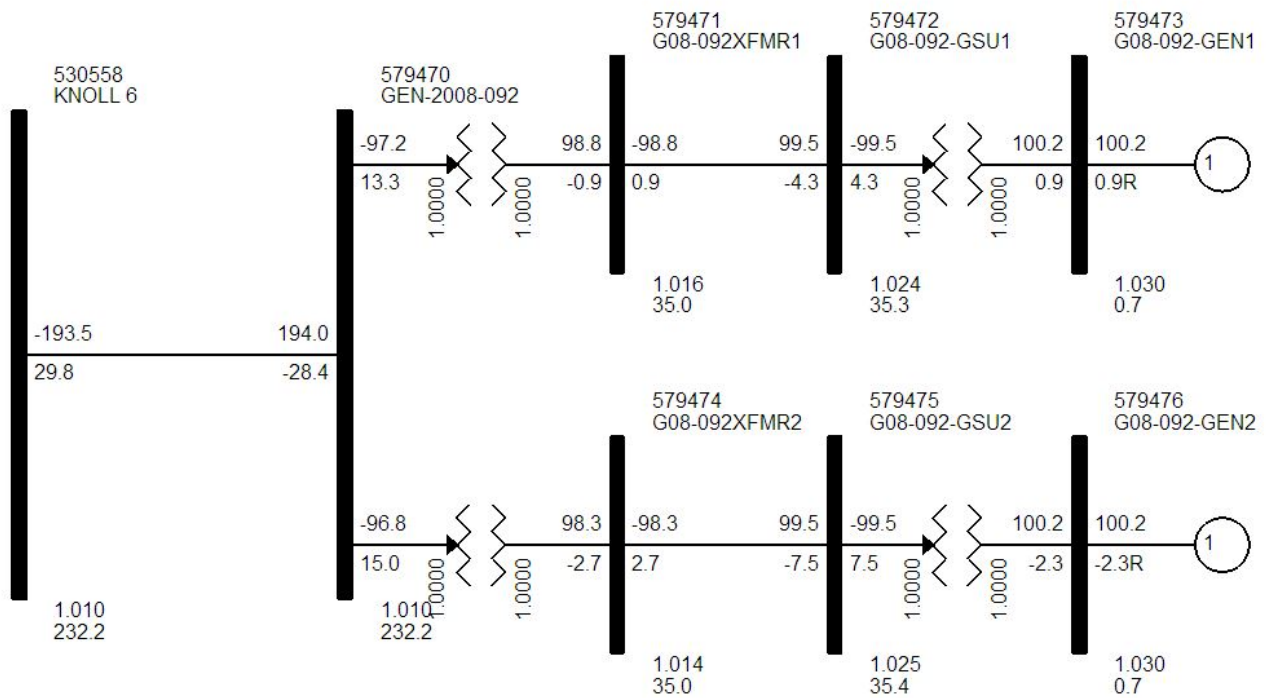

Figure 2-1: Proposed POI and Power Flow Model for GEN-2008-092

3. Stability Analysis

Transient stability analysis is used to determine if the transmission system can maintain angular stability and ensure bus voltages stay within planning criteria bandwidth during and after a disturbance while considering the addition of a generator interconnection request. Since the GE 1.79MW wind turbine generator is electrically similar to the GE 1.5MW wind turbine generator, a stability analysis was not performed. The analysis performed in the previous study is still valid.

4. Power Factor Analysis

The power factor analysis was not performed for this change request. The power factor analysis performed in the previous study is still valid. The final power factor requirement for GEN-2008-092 will be the pro-forma 95% lagging to 95% leading at the POI.

5. Reduced Generation Analysis

Interconnection requests for wind generation projects that interconnect to a 345kV or 230kV bus on the SPP system are analyzed for the capacitive charging effects during reduced generation conditions (due to unsuitable wind speeds, curtailment, etc.) at the generation site.

Model Preparation

The project generators and capacitors (if any), and all other wind projects that share the same POI, were turned off in the base case. The resulting reactive power injection into the transmission network comes from the capacitance of the project's transmission lines and collector cables. This reactive power injection is measured at the POI. Shunt reactors were added at the study project substation low voltage bus to bring the MVAR flow into the POI down to approximately zero.

Results

A final shunt reactor requirement for each of the studied interconnection requests is shown in **Table 5-1**. The results shown are for the 2015 summer case. The other two cases (2015 winter and 2025 summer) were almost identical since the generation plant design is the same in all cases.

Table 5-1: Summary of Shunt Reactor Requirements

Request	Capacity	POI	Approximate Shunt Reactor Required
GEN-2008-092	200.48MW	Hays 230kV Substation	12.4MVAR

One line drawings used in the analysis are shown in **Figure 5-1** and **Figure 5-2**. **Figure 5-1** shows reactor bank implementation (total of 12.4MVAR) at the low side (34.5kV) bus of the project's substation transformers to limit the generator facility reactive power injection into the POI to zero MVAR. **Figure 5-2** shows the GE WindFREE™ Reactive Power option implementation to limit the reactive power injection.

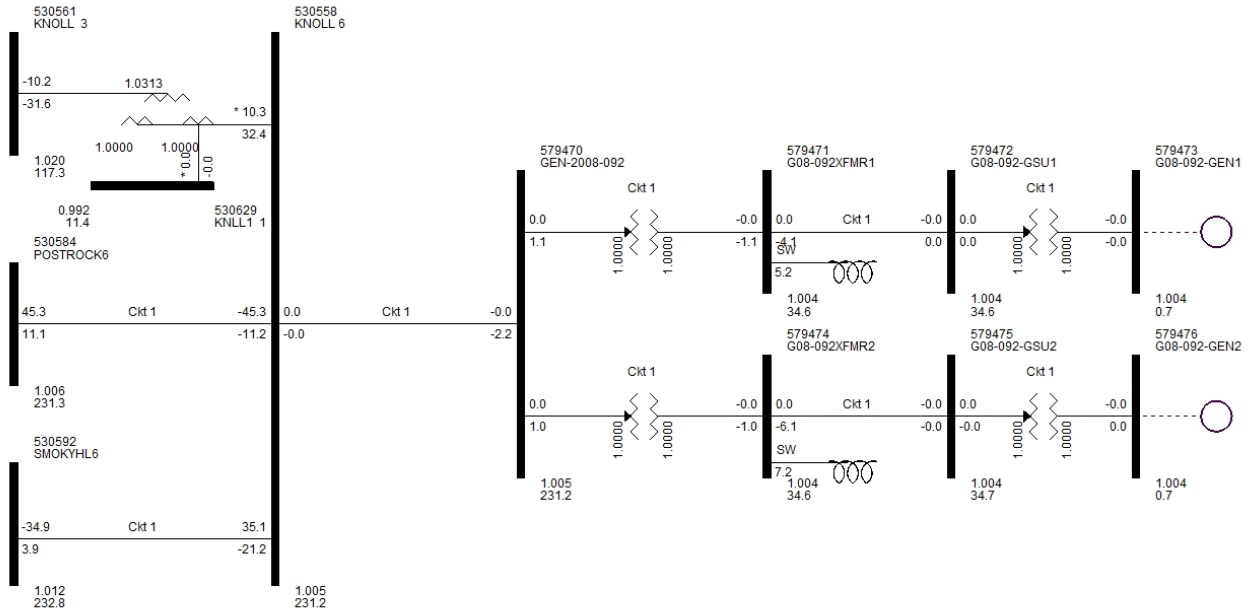

Figure 5-1: GEN-2008-092 with generators turned off and shunt reactors added to the low side of the substation 230/34.5kV transformer.

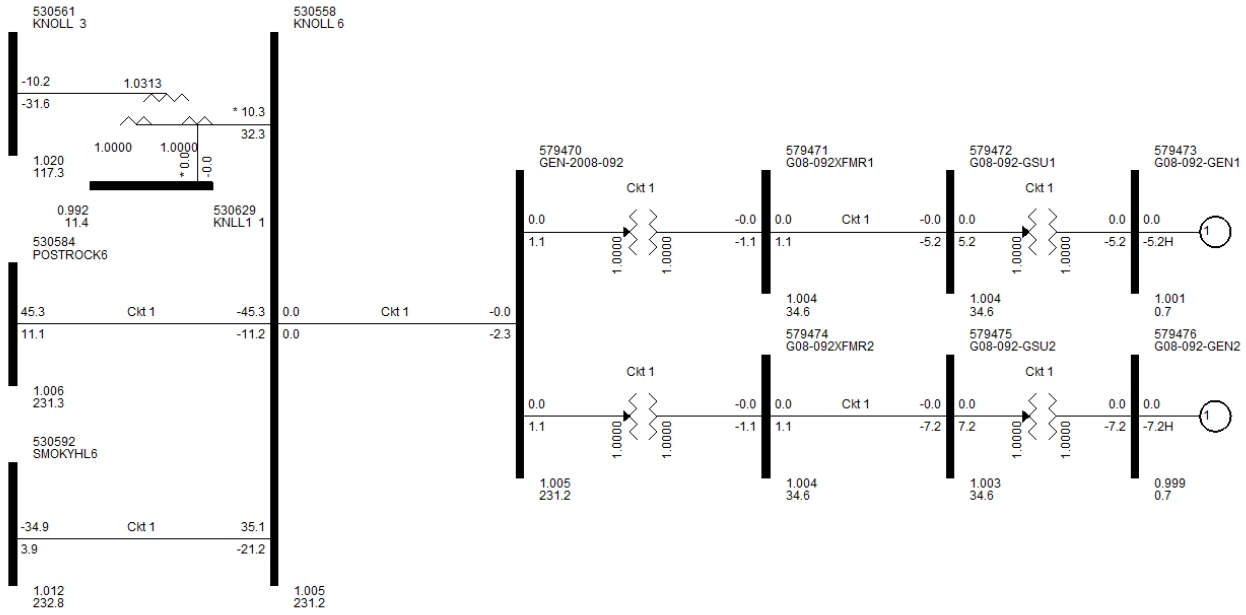

Figure 5-2: GEN-2008-092 with GE WindFREE™ Reactive Power option installed. Generators on line, power set to 0MW, reactive power set (-12.4MVAR) to limit reactive power injection to POI.

6. Conclusion

The GEN-2008-092 Interconnection Customer has requested a modification to its Generator Interconnection Agreement to change from GE 1.7MW wind turbine generators to the GE 1.79MW wind turbine generator. The GE 1.79MW wind turbine generator is electrically identical to the GE 1.7MW and GE 1.5MW wind turbine generators. Since GEN-2008-092 was studied previously using the GE 1.5MW wind turbine generators, the results of that study are still applicable to GEN-2008-092 using the GE 1.79MW wind turbine generators.

A reduced generation analysis was performed for the interconnection request to account for the change in the collector system. GEN-2008-092 will be required to install approximately 12.4MVAR of reactors. The reactor requirements can be implemented by external reactor banks or other means such as the GE WindFREE™ Reactive Power option.

Power factor requirements for GEN-2008-092 from the previous impact study are still valid. The interconnection request will be required to maintain the pro-forma +/- 0.95 power factor at the POI.

Nothing in this study should be construed as a guarantee of delivery or transmission service. If the customer wishes to sell power from the facility, a separate request for transmission service must be requested on Southwest Power Pool's OASIS by the Customer.